

MAXSYS®

PC4400 v2.0 • Installation Guide

WARNING: *This manual contains information on limitations regarding product use and function and information on the limitations as to liability of the manufacturer. The entire manual should be carefully read.*

WARNING Please Read Carefully

Note to Installers

This warning contains vital information. As the only individual in contact with system users, it is your responsibility to bring each item in this warning to the attention of the users of this system.

System Failures

This system has been carefully designed to be as effective as possible. There are circumstances, however, involving fire, burglary, or other types of emergencies where it may not provide protection. Any alarm system of any type may be compromised deliberately or may fail to operate as expected for a variety of reasons. Some but not all of these reasons may be:

■ **Inadequate Installation**

A security system must be installed properly in order to provide adequate protection. Every installation should be evaluated by a security professional to ensure that all access points and areas are covered. Locks and latches on windows and doors must be secure and operate as intended. Windows, doors, walls, ceilings and other building materials must be of sufficient strength and construction to provide the level of protection expected. A reevaluation must be done during and after any construction activity. An evaluation by the fire and/or police department is highly recommended if this service is available.

■ **Criminal Knowledge**

This system contains security features which were known to be effective at the time of manufacture. It is possible for persons with criminal intent to develop techniques which reduce the effectiveness of these features. It is important that a security system be reviewed periodically to ensure that its features remain effective and that it be updated or replaced if it is found that it does not provide the protection expected.

■ **Access by Intruders**

Intruders may enter through an unprotected access point, circumvent a sensing device, evade detection by moving through an area of insufficient coverage, disconnect a warning device, or interfere with or prevent the proper operation of the system.

■ **Power Failure**

Control units, intrusion detectors, smoke detectors and many other security devices require an adequate power supply for proper operation. If a device operates from batteries, it is possible for the batteries to fail. Even if the batteries have not failed, they must be charged, in good condition and installed correctly. If a device operates only by AC power, any interruption, however brief, will render that device inoperative while it does not have power. Power interruptions of any length are often accompanied by voltage fluctuations which may damage electronic equipment such as a security system. After a power interruption has occurred, immediately conduct a complete system test to ensure that the system operates as intended.

■ **Failure of Replaceable Batteries**

This system's wireless transmitters have been designed to provide several years of battery life under normal conditions. The expected battery life is a function of the device environment, usage and type. Ambient conditions such as high humidity, high or low temperatures, or large temperature fluctuations may reduce the expected battery life. While each transmitting device has a low battery monitor which identifies when the batteries need to be replaced, this monitor may fail to operate as expected. Regular testing and maintenance will keep the system in good operating condition.

■ **Compromise of Radio Frequency (Wireless) Devices**

Signals may not reach the receiver under all circumstances which could include metal objects placed on or near the radio path or deliberate jamming or other inadvertent radio signal interference.

■ **System Users**

A user may not be able to operate a panic or emergency switch possibly due to permanent or temporary physical disability, inability to reach the device in time, or unfamiliarity with the correct operation. It is important that all system users be trained in the correct operation of the alarm system and that they know how to respond when the system indicates an alarm.

■ **Smoke Detectors**

Smoke detectors that are a part of this system may not properly alert occupants of a fire for a number of reasons, some of which follow. The smoke detectors may have been improperly installed or positioned. Smoke may not be able to reach the smoke detectors, such as when the fire is in a chimney, walls or roofs, or on the other side of closed doors. Smoke detectors may not detect smoke from fires on another level of the residence or building.

Every fire is different in the amount of smoke produced and the rate of burning. Smoke detectors cannot sense all types of fires equally well. Smoke detectors may not provide timely warning of fires caused by carelessness or safety hazards such as smoking in bed, violent explosions, escaping gas, improper storage of flammable materials, overloaded electrical circuits, children playing with matches or arson.

Even if the smoke detector operates as intended, there may be circumstances when there is insufficient warning to allow all occupants to escape in time to avoid injury or death.

■ **Motion Detectors**

Motion detectors can only detect motion within the designated areas as shown in their respective installation instructions. They cannot discriminate between intruders and intended occupants. Motion detectors do not provide volumetric area protection. They have multiple beams of detection and motion can only be detected in unobstructed areas covered by these beams. They cannot detect motion which occurs behind walls, ceilings, floor, closed doors, glass partitions, glass doors or windows. Any type of tampering whether intentional or unintentional such as masking, painting, or spraying of any material on the lenses, mirrors, windows or any other part of the detection system will impair its proper operation.

Passive infrared motion detectors operate by sensing changes in temperature. However their effectiveness can be reduced when the ambient temperature rises near or above body temperature or if there are intentional or unintentional sources of heat in or near the detection area. Some of these heat sources could be heaters, radiators, stoves, barbecues, fireplaces, sunlight, steam vents, lighting and so on.

■ **Warning Devices**

Warning devices such as sirens, bells, horns, or strobes may not warn people or waken someone sleeping if there is an intervening wall or door. If warning devices are located on a different level of the residence or premise, then it is less likely that the occupants will be alerted or awakened. Audible warning devices may be interfered with by other noise sources such as stereos, radios, televisions, air conditioners or other appliances, or passing traffic. Audible warning devices, however loud, may not be heard by a hearing-impaired person.

■ **Telephone Lines**

If telephone lines are used to transmit alarms, they may be out of service or busy for certain periods of time. Also an intruder may cut the telephone line or defeat its operation by more sophisticated means which may be difficult to detect.

■ **Insufficient Time**

There may be circumstances when the system will operate as intended, yet the occupants will not be protected from the emergency due to their inability to respond to the warnings in a timely manner. If the system is monitored, the response may not occur in time to protect the occupants or their belongings.

■ **Component Failure**

Although every effort has been made to make this system as reliable as possible, the system may fail to function as intended due to the failure of a component.

■ **Inadequate Testing**

Most problems that would prevent an alarm system from operating as intended can be found by regular testing and maintenance. The complete system should be tested weekly and immediately after a break-in, an attempted break-in, a fire, a storm, an earthquake, an accident, or any kind of construction activity inside or outside the premises. The testing should include all sensing devices, keypads, consoles, alarm indicating devices and any other operational devices that are part of the system.

■ **Security and Insurance**

Regardless of its capabilities, an alarm system is not a substitute for property or life insurance. An alarm system also is not a substitute for property owners, renters, or other occupants to act prudently to prevent or minimize the harmful effects of an emergency situation.

Limited Warranty

Digital Security Controls Ltd. warrants the original purchaser that for a period of twelve months from the date of purchase, the product shall be free of defects in materials and workmanship under normal use. During the warranty period, Digital Security Controls Ltd. shall, at its option, repair or replace any defective product upon return of the product to its factory, at no charge for labour and materials. Any replacement and/or repaired parts are warranted for the remainder of the original warranty or ninety (90) days, whichever is longer. The original owner must promptly notify Digital Security Controls Ltd. in writing that there is defect in material or workmanship, such written notice to be received in all events prior to expiration of the warranty period.

International Warranty

The warranty for international customers is the same as for any customer within Canada and the United States, with the exception that Digital Security Controls Ltd. shall not be responsible for any customs fees, taxes, or VAT that may be due.

Warranty Procedure

To obtain service under this warranty, please return the item(s) in question to the point of purchase. All authorized distributors and dealers have a warranty program. Anyone returning goods to Digital Security Controls Ltd. must first obtain an authorization number. Digital Security Controls Ltd. will not accept any shipment whatsoever for which prior authorization has not been obtained.

Conditions to Void Warranty

This warranty applies only to defects in parts and workmanship relating to normal use. It does not cover:

- damage incurred in shipping or handling;
- damage caused by disaster such as fire, flood, wind, earthquake or lightning;
- damage due to causes beyond the control of Digital Security Controls Ltd. such as excessive voltage, mechanical shock or water damage;
- damage caused by unauthorized attachment, alterations, modifications or foreign objects;
- damage caused by peripherals (unless such peripherals were supplied by Digital Security Controls Ltd.);
- defects caused by failure to provide a suitable installation environment for the products;
- damage caused by use of the products for purposes other than those for which it was designed;
- damage from improper maintenance;
- damage arising out of any other abuse, mishandling or improper application of the products.

Digital Security Controls Ltd.'s liability for failure to repair the product under this warranty after a reasonable number of attempts will be limited to a replacement of the product, as the exclusive remedy for breach of warranty. Under no circumstances shall Digital Security Controls Ltd. be liable for any special, incidental, or consequential damages based upon breach of warranty, breach of contract, negligence, strict liability, or any other legal theory. Such damages include, but are not limited to, loss of profits, loss of the product or any associated equipment, cost of capital, cost of substitute or replacement equipment, facilities or services, down time, purchaser's time, the claims of third parties, including customers, and injury to property.

Disclaimer of Warranties

This warranty contains the entire warranty and shall be in lieu of any and all other warranties, whether expressed or implied (including all implied warranties of merchantability or fitness for a particular purpose) And of all other obligations or liabilities on the part of Digital Security Controls Ltd. Digital Security Controls Ltd. neither assumes responsibility for nor authorizes any other person purporting to act on its behalf to modify or to change this warranty, nor to assume for it any other warranty or liability concerning this product.

This disclaimer of warranties and limited warranty are governed by the laws of the province of Ontario, Canada.

WARNING: Digital Security Controls Ltd. recommends that the entire system be completely tested on a regular basis. However, despite frequent testing, and due to, but not limited to, criminal tampering or electrical disruption, it is possible for this product to fail to perform as expected.

Installer's Lockout

Any products returned to DSC which have the Installer's Lockout option enabled and exhibit no other problems will be subject to a service charge.

Out of Warranty Repairs

Digital Security Controls Ltd. will at its option repair or replace out-of-warranty products which are returned to its factory according to the following conditions. Anyone returning goods to Digital Security Controls Ltd. must first obtain an authorization number. Digital Security Controls Ltd. will not accept any shipment whatsoever for which prior authorization has not been obtained.

Products which Digital Security Controls Ltd. determines to be repairable will be repaired and returned. A set fee which Digital Security Controls Ltd. has predetermined and which may be revised from time to time, will be charged for each unit repaired.

Products which Digital Security Controls Ltd. determines not to be repairable will be replaced by the nearest equivalent product available at that time. The current market price of the replacement product will be charged for each replacement unit.

1.	Introduction	1
2.	Specifications	1
	PC4400 connected to a serial printer	1
	PC4400 connected to a DVAC network	1
3.	Installing the PC4400	1
	3.1 Unpacking	1
	3.2 Mounting the Cabinet	1
	3.3 Wiring	1
	3.4 PC4400 Hookup Diagram	2
	3.5 Applying Power	2
4.	Enrolling the Module	3
5.	Programming the Module	3
	5.1 Baud Rate	3
	5.2 DVAC Options	3
	5.3 DVAC Identifiers	3
	5.4 Default DVAC	6
	5.5 Trouble Conditions	6
	Programming Worksheets	7
	Baud Rate	7
	DVAC Options	7
	Default DVAC Programming	7
	DVAC Identifiers	8
	Zone X Alarm/Restore	8
	DVAC Identifiers	9
	Zone X Trouble/Restore	9
	Zone X Fault/Restore	10
	Module Tamper/Restore	11
	Priority Alarms	11
	Openings and Closings by User	12
	Miscellaneous Openings and Closings	13
	Partition Openings and Closings	13
	System Maintenance	13
	PC4204 Troubles	13
	Fire Module	13
	Wireless – Low Batter	14
	Wireless – Low Battery	14
	Police Code (PC)	14
	DVAC Module	14
	DVAC Identifiers	15
	Function Bytes	15
	Alarm Function Bytes	15
	Trouble Function Bytes	15
	Bypass Function Bytes	16
	Supervisory Function Bytes	16
	Opening and Closing Function Bytes	16
	Miscellaneous Function Bytes	17
	7E/FE : Specific Message Function Byte	17

Table of Contents

1.	Introduction	1
2.	Specifications	1
	PC4400 connected to a serial printer	1
	PC4400 connected to a DVAC network	1
3.	Installing the PC4400	1
3.1	Unpacking	1
3.2	Mounting the Cabinet	1
3.3	Wiring	1
3.4	PC4400 Hookup Diagram	2
3.5	Applying Power	2
4.	Enrolling the Module	3
5.	Programming the Module	3
5.1	Baud Rate	3
5.2	DVAC Options	3
5.3	DVAC Identifiers	3
5.4	Default DVAC	6
5.5	Trouble Conditions	6
Programming Worksheets		7
	Baud Rate	7
	DVAC Options	7
	Default DVAC Programming	7
	DVAC Identifiers	8
	Zone X Alarm/Restore	8
	DVAC Identifiers	9
	Zone X Trouble/Restore	9
	Zone X Fault/Restore	10
	Module Tamper/Restore	11
	Priority Alarms	11
	Openings and Closings by User	12
	Miscellaneous Openings and Closings	13
	Partition Openings and Closings	13
	System Maintenance	13
	PC4204 Troubles	13
	Fire Module	13
	Wireless – Low Batter	14
	Wireless – Low Battery	14
	Police Code (PC)	14
	DVAC Module	14
DVAC Identifiers		15
	Function Bytes	15
	Alarm Function Bytes	15
	Trouble Function Bytes	15
	Bypass Function Bytes	16
	Supervisory Function Bytes	16
	Opening and Closing Function Bytes	16
	Miscellaneous Function Bytes	17
	7E/FE : Specific Message Function Byte	17

1. Introduction

The PC4400 module adds serial printer or DVAC communications capability to a MAXSYS PC4010 or PC4020 security system.

2. Specifications

- Four wire (QUAD) hook-up to Combus
- Normal current draw of 35 mA
- Tamper and Trouble reporting codes
- Low Combus supervision to Main Control Panel
- Maximum cable length: 200 feet (61 meters)

PC4400 connected to a serial printer:

- True RS-232 technology
- Protocol XON/XOFF or DTR
- Five possible baud rates: 300, 600, 1200, 2400 or 4800

NOTE: 4800 Baud only available on PC4010/PC4020 V2.1 and above.

PC4400 connected to a DVAC network:

- Automatic programming for DVAC function bytes and reporting codes.
- Programmable response type to all calls
- Monitoring for DVAC Line fault
- Module self diagnostics

3. Installing the PC4400

3.1 Unpacking

The PC4400 package includes the following parts:

- One PC4400 circuit board
- Four plastic stand-offs

3.2 Mounting the Cabinet

When mounting a new cabinet for the PC4400, select a dry location close to either the serial printer or the F1/F2 subsets if DVAC communication is to be used.

To mount the cabinet:

1. From the back of the cabinet, press in the four white circuit board stand-offs into the raised mounting holes.
2. Holding the cabinet in position, pull all wiring into the cabinet through the hole in the back.
3. Using the provided mounting screws and appropriate wall anchors, mount the cabinet securely to the wall.
4. Press the PC4400 module onto the plastic stand-offs.

3.3 Wiring

Before beginning to wire the unit, ensure that all power (AC transformer and battery) is disconnected from the control panel.

Perform the following steps to complete wiring:

1. Connect the four Combus wires to the PC4400. Connect the red, black, yellow and green Combus wires to the RED, BLK, YEL and GRN terminals, respectively.
2. Connect terminals T1 and T2 to a normally closed tamper switch. If no tamper switch is desired, connect a jumper wire between T1 and T2 terminals.

Consult the wiring diagram on page 2 for further information.

3.4 PC4400 Hookup Diagram

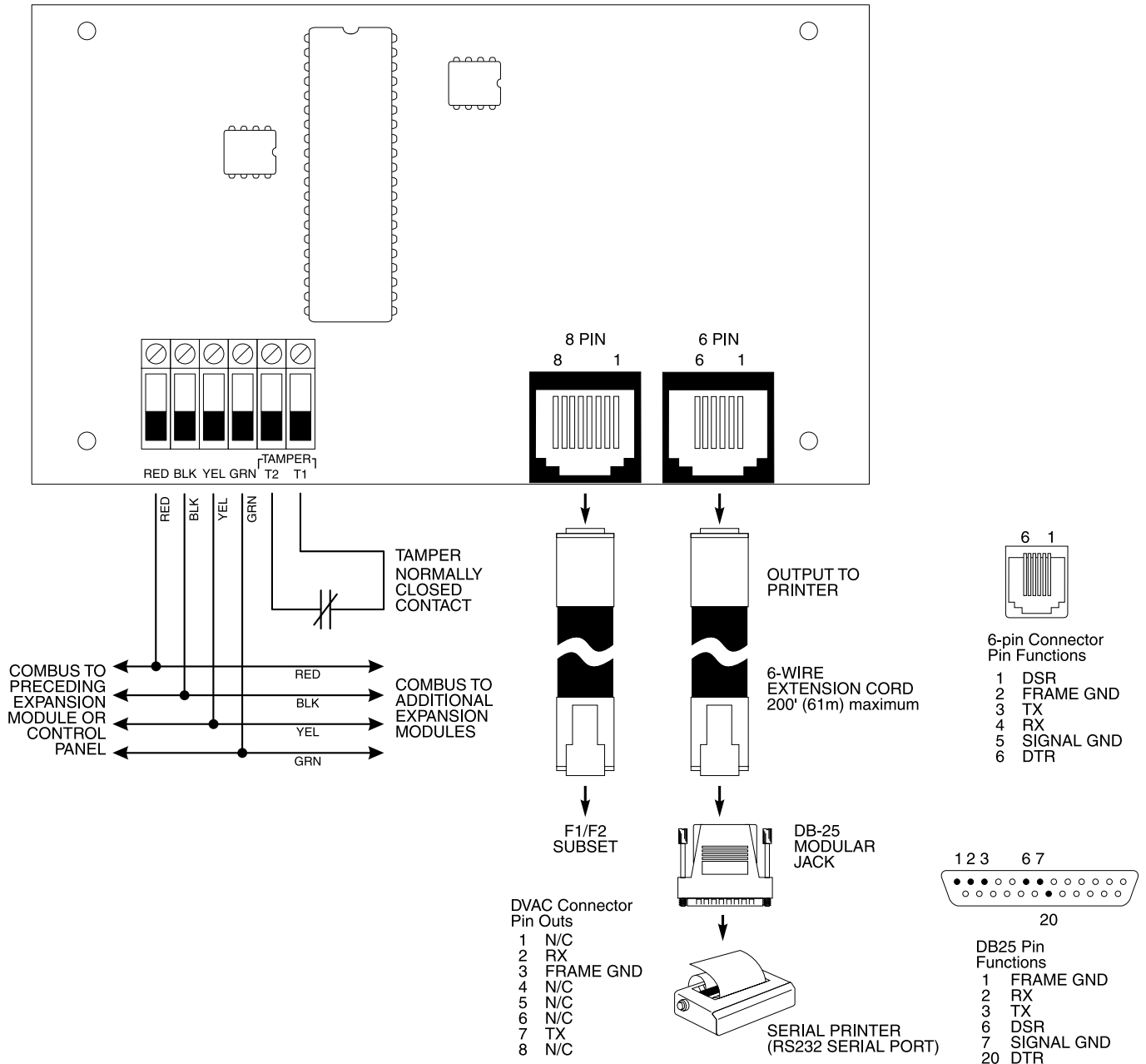

3.5 Applying Power

After all wiring is completed, apply power to the control panel. Connect the battery leads to the battery, then connect the AC transformer. For more information on control panel power specifications, see the control panel Installation Manual.

NOTE: Do not connect the power until all wiring is complete.

4. Enrolling the Module

Once all wiring is complete, you must enroll the module:

1. Enter installer's programming by pressing [*] [8] [Installer's Code].
2. Scroll to "Module Hardware" and press the [*] key.
3. Scroll to "Enroll Module" and press the [*] key.
4. Scroll through the different modules until "PC4400" is displayed. Press the [*] key.
5. The message "Create Tamper on Desired Unit" will be displayed. To create the required tamper, secure the tamper zone on the module and then open it. The transition from secure to violated enrolls the module. After this is done, the keypad will display the module number and will confirm enrollment (e.g. "PC4400 Mod 01 Enrolled").
6. The panel will prompt "Select Toggle <> DVAC enabled N". To enable the module for DVAC communications, press [*]. The display changes to "DVAC enabled Y". To use the module with a serial printer, leave the toggle set to "DVAC enabled N".

NOTE: To change the DVAC enabled toggle option for the module, you must remove, and then re-enroll the module.

For more information regarding module enrollment, see the control panel Installation Manual.

5. Programming the Module

To access PC4010/PC4020 programming, enter [*][8] followed by the Installer's code. The sections you will need to program are described below. For more information regarding programming, see the control panel Installation Manual.

The PC4400 module programming sections are located in the System Area section under the PC4400 options. Once you have entered installer's programming, enter the indicated reference number (on PC4010/PC4020 v3.x panels only); OR use the [<] [>] keys to scroll through the programming options on the LCD display and press [*] to select the desired option.

The following explains each programming option relevant to the PC4400.

5.1 Baud Rate

Ref. # [000800]

This section is used to program which baud rate the PC4400 serial interface module will use to communicate with a serial printer. The baud rate is the speed at which information will be transmitted from the PC4400 module to the serial printer. There are five different baud rates available to the PC4400 module: 300, 600, 1200, 2400 and 4800 baud. If you are experiencing problems with missing characters, try lowering the baud rate.

NOTE: 4800 Baud only available on PC4010/PC4020 V2.1 and above.

5.2 DVAC Options

Ref. # [00080100]

This section is used to program DVAC options for the PC4400 module.

NOTE: This section is only available if the PC4400 module is enrolled as a DVAC module.

ID Code Option

This is the ID code the PC4400 module will use for DVAC communications. Valid ID codes range from 01 to EF. The default ID code is FF. With this setting, the PC4400 will respond to ID code 01.

NOTE: Do not plug the DVAC line into the module until the ID code has been programmed.

All Call Select Options

This option determines how the PC4400 module will respond to all calls from the central station. The valid entries are from 00 to 04:

00 = No response on all calls.

01 = Respond to all call #1 only.

02 = Respond to all call #2 only.

03 = Respond to both all calls.

04 = Respond to all call #1 if ID code is odd or on all call #2 if ID code is even.

The default all call setting is FF. With this setting, the PC4400 will follow the all call option 04.

5.3 DVAC Identifiers

Ref. # [00080101]

This section is used to program the function byte and reporting code for the events transmitted over the DVAC. After entering this section, the installer will be prompted to enter a reporting code number. Valid entries are from 0000 to 0346.

NOTE: System tests are not transmitted through DVACS.

Special Function Byte (FB) Values

FF = Transmit the default FB

Special Reporting Code (RC) Values

000 = Disable transmission

254 = Transmit a zero

255 = Transmit the default RC

NOTE: When programming a section, if the panel loses communications with the PC4400 module, the message "DVAC module not present" will be displayed. If this occurs check your wiring, then program the section again.

The following is a list of the default DVAC reporting and identifier codes:

Rep #	Title	FB	RC	Printed Message
0000 - 007F	Zone Alarms/Restore	*	001 - 128	(See Zone Events Section)
0080 - 00FF	Zone Troubles/Restore	*	001 - 128	(See Zone Events Section)
0100 - 017F	Zone Faults/Restore	*	001 - 128	(See Zone Events Section)
0180 - 01C9	Module (1-74) Tamper/Restore	17/97	131 - 204	Tamper Zn#
01CA	Fire Key	00	129	Fire Zn#129
01CB	Aux. Key	04	129	Medical Zn# 0129
01CC	Panic Key	02	129	Panic Zn#129
01CD	Duress Code	03	129	Holdup Zn#129
01CE - 024D	Open/Close by users	76/F6	001 - 128	Open/Close User#
024E	Quick Arm	F6	130	Close User#130
024F	Partial Close	7E	004	PartClos
0250	Auto Arm Abort	7E	011	Late to Close
0251	Automatic Arming	7E	001	Automat Closing
0252	Keypad Lockout	7E	029	User cd Tamper
0253	Open/Close second Master	76/F6	131	Close User#131
0254 - 0256	For Future Use	00	—	Not Transmitted
0257	Opening after Alarm	7E	017	Disarm from alm
0258	Auto Disarm	7E	002	Automatic Open
0259 - 0260	Partition Open/Close	77/F7	001 - 008	Open/Close Group#
0261	For Future Use	00	—	Not Transmitted
0262	System Battery Trouble/Restore	3D/BD	001	SysLBat
0263	System AC Trouble/Restore	3A/BA	001	AC Cut
0264	System Bell Trouble/Restore	32/B2	135	System trb
0265	System Aux. Supply Trouble/Restore	3C/BC	001	PwSupply
0266	Combus Trouble/Restore	32/B2	131	System trb
0267 - 0268	TLM Line 1 & 2 Trouble/Restore	3E/BE	001 - 002	Line
0269	FTC Restoral	00	—	Not Transmitted
026A	System Periodic Test	00	—	Not Transmitted
026B	Event Buffer %75 Full	32	132	System trb
026C	System Test	00	—	Not Transmitted
026D	LINKS Periodic Test	00	—	Not Transmitted
026E	Periodic UL Test	7A	002	Test
026F	DLS Lead In	7E	047	Remote P. Begin
0270	DLS Lead Out	7E	049	Remote P. Success
0271	Installer Lead In	7E	039	Local Prg Begin
0272	Installer Lead Out	7E	043	Local Prg Ended
0273	Automation Fault/Restore	32/B2	133	System Trb
0274 - 0277	For Future Use	00	—	Not Transmitted
0278 - 02A7	PC4204 Battery Trouble/Restore	3D/BD	011 - 026	SysLBat
	PC4204 AC Trouble/Restore	3A/BA	011 - 026	AC Cut
	PC4204 Aux. Supply Trb/Restore	3C/BC	011 - 026	PwSupply
02A8	For Future Use	00	—	Not Transmitted
02A9	Fire Alarm 2-wire Smoke	00/80	130	Fire
02AA	Water Flow Alarm	01/81	130	Sprnklr
02AB	2-wire Smoke Trouble	20/A0	130	Fire Trb
02AC	Water Flow Trouble	21/A1	130	Sprnklr Trb
02AD	Ground Fault	32/B2	130	System Trb
02AE - 02ED	Wireless Zone Low Batt. Alarm	3B/BB	151 - 214	WirLBat

The above events apply to PC40x0 v2.1x

02EE - 032D	Wireless Zone Supervisory	18/98	151 - 214	Supervi
032E - 0335	Partition Police (1 - 8) ◆	19/99	001 - 008	Burglary Verified
0336-0337	For Future Use	00	—	Not Transmitted
0338	DVAC Line Fault	3E/BE	004	Line
0339	DVAC Module Fault	32/B2	137	System Trb
033A	DVAC Shut Down By C.S.	32/B2	138	System Trb
033B	Bypassed Zone ■	*	001 - 128	(See Zone Events Section)
033C-0346	For Future Use	00	—	Not Transmitted

◆ **Partition Police Code restoral not transmitted by DVAC module.**

■ **To disable this transmission, program the function byte as "00" and the reporting code as "000". Programming any other values will result in the transmission of the default settings.**

If the reporting code is left as default FF, it will be the same as the zone number and the function byte for the zone events will be the corresponding zone type. A zone has seven associated events that will modify the printer message.

The following is a list of changes of DVAC reporting codes that apply to the PC40x0 v3.0 only.

Rep #	Title	FB	RC	Printed Message
1CA	Fire Key Alarm/Restores	00	129	Fire Alm/Rst Zn#129
1CB	Aux. Key Alarm/Restore	04	129	Medical Alm/Rst Zn#129
1CC	Panic Key Alarm/Resotres	02	129	Panic Alm.Rst Zn#129
24E	Quick Arm	F6	130	Not Transmitted
24F	Partial Close	7E	004	Partial Closing
278-2A7	PC4204 Battery Trouble/Restore	3D/BD	011-026	Not Transmitted
	PC4204 AC Trouble/Restore	3A/BA	011-026	Not Transmitted
	PC4204 Aux. Supply Trb/Restore	3C/BC	011-026	Not Transmitted
2EE-32D	Wireless Zone Supervisory	18/98	151-214	Not Transmitted
338	DVAC Line Fault	3E/BE	004	Not Transmitted
339	DVAC Module Fault	32/B2	137	Not Transmitted
33A	DVAC Shut Down by C.S.	32/B2	138	Not Transmitted

Zone Events

PC4020 Event	DVAC Printer MSG	PC4020 Event	DVAC Printer MSG
Zone Alarm.....	Alm	Zone Trouble/Tamper Restore.....	T_R
Zone Restore.....	Rst	Zone Fault.....	Sup
Partial Closing+ Zone Alarm.....	Byp	Zone Fault Restore.....	S_R
Zone Trouble/TamperTrb.....	Trb		

The following is a list of the default settings for zone transmissions:

Zone Type	FB:	Alm	Rst	Byp	Trb	T_R	Sup	S_R	Printer MSG
Standard Delay		08	88	48	28	A8	68	E8	Delay
Aux. Delay		08	88	48	28	A8	68	E8	Delay
Instant		09	89	49	29	A9	69	E9	Instant
Interior		0A	8A	4A	2A	AA	6A	EA	Interior
Interior H.A		0B	8B	4B	2B	AB	6B	EB	InteriHA
Delay H.A		07	87	47	27	A7	67	E7	DelayHA
24 hr Bell *		11	91	51	31	B1	71	F1	24 hr
24 hr Bell/Buzzer		11	91	51	31	B1	71	F1	24 hr
24 hr Buzzer		11	91	51	31	B1	71	F1	24 hr
Standard Fire		00	80	40	20	A0	60	E0	Fire
Delayed Fire		00	80	40	20	A0	60	E0	Fire
Auto Ver. Fire		00	80	40	20	A0	60	E0	Fire
Momentary Arm	XX								
Maintained Arm	XX								
Latching 24 hr		16	96	56	36	B6	76	F6	24hrLat
Forced Answer	XX								
Links Supervisory		18	98	58	38	B8	78	F8	Supervi
Links Answer	XX								
Sprinkler		01	81	41	21	A1	61	E1	Sprnklr
Hold Up		03	83	43	23	A3	63	E3	Hold Up
Panic		02	82	42	22	A2	62	E2	Panic
Technical		18	98	58	38	B8	78	F8	Supervi

* The following zone types transmit as 24 hr Bell: 24 hr Gas, 24 hr Heat, 24 hr Medical, 24 hr Emergency, 24 hr Water, 24 hr Freeze.

The list below shows the new zone types that apply to the PC40x0 v3.0 only.

Zone Type FB:	Alm	Rst	Byp	Trb	T_R	Sup	S_R	Printer MSG
Interior Delay	0A	8A	4A	2A	AA	6A	EA	Interior
Waterflow	00	80	40	20	A0	60	E0	Fire
Fire Supervisory	01	81	41	21	A1	61	E1	Sprinkler

5.4 Default DVAC

Ref. # [00080102]

This command will restore the PC4400 programming back to the default values. After you enter this section, you will be prompted to confirm returning the PC4400 to its default settings by pressing the [*] key. The default process has a duration of 10-15 seconds.

NOTE: *When exiting installer's mode, if the panel loses communication with the PC4400 module, the message "DVAC module not present" will be displayed. If this occurs, check your wiring, then enter and exit the installer's programming mode again.*

If the Periodic UL Test reporting code is removed from the panel, the DVAC Periodic UL Test transmission will not be sent.

5.5 Trouble Conditions

The control panel always watches for possible trouble conditions. If a trouble condition occurs, the keypad "Trouble" light will turn on and the keypad will beep. Press [*][2] to display the trouble conditions.

The following trouble conditions apply to the PC4400 module. For a description of all troubles, please see your system Installation Manual. Reporting codes for these troubles can be programmed (ref. # [000403] OR scroll to

System Area, then **Communicator**, then **Reporting Codes**).

- Printer Off-line
- PC4400 Trouble

If programmed, the panel can also send reporting codes for the following conditions:

- General System Tamper Alarm (PC4010/4020 v3.x and higher)
- General System Tamper Restore (PC4010/4020 v3.x and higher)
- General System Trouble (reported for DVAC Trouble on PC4010/4020 v3.x and higher)
- General System Trouble Restore (reported for DVAC Trouble Restore on PC4010/4020 v3.x and higher)
- PC4400 Tamper Alarm (PC4010/4020 v2.1 and lower)
- PC4400 Tamper Restore (PC4010/4020 v2.1 and lower)
- RS-232 Trouble (PC4010/4020 v2.1 and lower)
- RS-232 Trouble Restore (PC4010/4020 v2.1 and lower)
- DVAC Trouble (PC4010/4020 v2.1 and lower)
- DVAC Trouble Restore (PC4010/4020 v2.1 and lower)

Record your reporting code choices in the panel's Programming Worksheets booklet.

Programming Worksheets

Baud Rate

REFERENCE # [000800]

300 600 1200
 2400 4800

DVAC Options

REFERENCE # [00080100]

ID Code Default = FF (Valid entries 01-FF)

All Call Select Default = FF (Valid entries 00-04)

00 = no response to all calls

01 = response to all call #1 only

02 = response to all call #2 only

03 = response to both all calls

04 = response to all call #1 if ID code is odd
or to all call #2 if ID code is even

Default DVAC Programming

REFERENCE # [00080102]

DVAC Identifiers

REFERENCE # [00080101]

Zone X Alarm/Restore

Rep #		FB	RC	Rep #		FB	RC	Rep #		FB	RC
0000	Zn 1	Alm/Rst		002B	Zn 44	Alm/Rst		0056	Zn 87	Alm/Rst	
0001	Zn 2	Alm/Rst		002C	Zn 45	Alm/Rst		0057	Zn 88	Alm/Rst	
0002	Zn 3	Alm/Rst		002D	Zn 46	Alm/Rst		0058	Zn 89	Alm/Rst	
0003	Zn 4	Alm/Rst		002E	Zn 47	Alm/Rst		0059	Zn 90	Alm/Rst	
0004	Zn 5	Alm/Rst		002F	Zn 48	Alm/Rst		005A	Zn 91	Alm/Rst	
0005	Zn 6	Alm/Rst		0030	Zn 49	Alm/Rst		005B	Zn 92	Alm/Rst	
0006	Zn 7	Alm/Rst		0031	Zn 50	Alm/Rst		005C	Zn 93	Alm/Rst	
0007	Zn 8	Alm/Rst		0032	Zn 51	Alm/Rst		005D	Zn 94	Alm/Rst	
0008	Zn 9	Alm/Rst		0033	Zn 52	Alm/Rst		005E	Zn 95	Alm/Rst	
0009	Zn 10	Alm/Rst		0034	Zn 53	Alm/Rst		005F	Zn 96	Alm/Rst	
000A	Zn 11	Alm/Rst		0035	Zn 54	Alm/Rst		0060	Zn 97	Alm/Rst	
000B	Zn 12	Alm/Rst		0036	Zn 55	Alm/Rst		0061	Zn 98	Alm/Rst	
000C	Zn 13	Alm/Rst		0037	Zn 56	Alm/Rst		0062	Zn 99	Alm/Rst	
000D	Zn 14	Alm/Rst		0038	Zn 57	Alm/Rst		0063	Zn 100	Alm/Rst	
000E	Zn 15	Alm/Rst		0039	Zn 58	Alm/Rst		0064	Zn 101	Alm/Rst	
000F	Zn 16	Alm/Rst		003A	Zn 59	Alm/Rst		0065	Zn 102	Alm/Rst	
0010	Zn 17	Alm/Rst		003B	Zn 60	Alm/Rst		0066	Zn 103	Alm/Rst	
0011	Zn 18	Alm/Rst		003C	Zn 61	Alm/Rst		0067	Zn 104	Alm/Rst	
0012	Zn 19	Alm/Rst		003D	Zn 62	Alm/Rst		0068	Zn 105	Alm/Rst	
0013	Zn 20	Alm/Rst		003E	Zn 63	Alm/Rst		0069	Zn 106	Alm/Rst	
0014	Zn 21	Alm/Rst		003F	Zn 64	Alm/Rst		006A	Zn 107	Alm/Rst	
0015	Zn 22	Alm/Rst		0040	Zn 65	Alm/Rst		006B	Zn 108	Alm/Rst	
0016	Zn 23	Alm/Rst		0041	Zn 66	Alm/Rst		006C	Zn 109	Alm/Rst	
0017	Zn 24	Alm/Rst		0042	Zn 67	Alm/Rst		006D	Zn 110	Alm/Rst	
0018	Zn 25	Alm/Rst		0043	Zn 68	Alm/Rst		006E	Zn 111	Alm/Rst	
0019	Zn 26	Alm/Rst		0044	Zn 69	Alm/Rst		006F	Zn 112	Alm/Rst	
001A	Zn 27	Alm/Rst		0045	Zn 70	Alm/Rst		0070	Zn 113	Alm/Rst	
001B	Zn 28	Alm/Rst		0046	Zn 71	Alm/Rst		0071	Zn 114	Alm/Rst	
001C	Zn 29	Alm/Rst		0047	Zn 72	Alm/Rst		0072	Zn 115	Alm/Rst	
001D	Zn 30	Alm/Rst		0048	Zn 73	Alm/Rst		0073	Zn 116	Alm/Rst	
001E	Zn 31	Alm/Rst		0049	Zn 74	Alm/Rst		0074	Zn 117	Alm/Rst	
001F	Zn 32	Alm/Rst		004A	Zn 75	Alm/Rst		0075	Zn 118	Alm/Rst	
0020	Zn 33	Alm/Rst		004B	Zn 76	Alm/Rst		0076	Zn 119	Alm/Rst	
0021	Zn 34	Alm/Rst		004C	Zn 77	Alm/Rst		0077	Zn 120	Alm/Rst	
0022	Zn 35	Alm/Rst		004D	Zn 78	Alm/Rst		0078	Zn 121	Alm/Rst	
0023	Zn 36	Alm/Rst		004E	Zn 79	Alm/Rst		0079	Zn 122	Alm/Rst	
0024	Zn 37	Alm/Rst		004F	Zn 80	Alm/Rst		007A	Zn 123	Alm/Rst	
0025	Zn 38	Alm/Rst		0050	Zn 81	Alm/Rst		007B	Zn 124	Alm/Rst	
0026	Zn 39	Alm/Rst		0051	Zn 82	Alm/Rst		007C	Zn 125	Alm/Rst	
0027	Zn 40	Alm/Rst		0052	Zn 83	Alm/Rst		007D	Zn 126	Alm/Rst	
0028	Zn 41	Alm/Rst		0053	Zn 84	Alm/Rst		007E	Zn 127	Alm/Rst	
0029	Zn 42	Alm/Rst		0054	Zn 85	Alm/Rst		007F	Zn 128	Alm/Rst	
002A	Zn 43	Alm/Rst		0055	Zn 86	Alm/Rst					

DVAC Identifiers

REFERENCE #[00080101]

Zone X Trouble/Restore

Rep #	FB	RC	Rep #	FB	RC	Rep #	FB	RC
0080 Zn 1 Trb/Rst			00AB Zn 44 Trb/Rst			00D6 Zn 87 Trb/Rst		
0081 Zn 2 Trb/Rst			00AC Zn 45 Trb/Rst			00D7 Zn 88 Trb/Rst		
0082 Zn 3 Trb/Rst			00AD Zn 46 Trb/Rst			00D8 Zn 89 Trb/Rst		
0083 Zn 4 Trb/Rst			00AE Zn 47 Trb/Rst			00D9 Zn 90 Trb/Rst		
0084 Zn 5 Trb/Rst			00AF Zn 48 Trb/Rst			00DA Zn 91 Trb/Rst		
0085 Zn 6 Trb/Rst			00B0 Zn 49 Trb/Rst			00DB Zn 92 Trb/Rst		
0086 Zn 7 Trb/Rst			00B1 Zn 50 Trb/Rst			00DC Zn 93 rb/Rst		
0087 Zn 8 Trb/Rst			00B2 Zn 51 Trb/Rst			00DD Zn 94 Trb/Rst		
0088 Zn 9 Trb/Rst			00B3 Zn 52 Trb/Rst			00DE Zn 95 Trb/Rst		
0089 Zn 10 Trb/Rst			00B4 Zn 53 Trb/Rst			00DF Zn 96 Trb/Rst		
008A Zn 11 Trb/Rst			00B5 Zn 54 Trb/Rst			00E0 Zn 97 Trb/Rst		
008B Zn 12 Trb/Rst			00B6 Zn 55 Trb/Rst			00E1 Zn 98 Trb/Rst		
008C Zn 13 Trb/Rst			00B7 Zn 56 Trb/Rst			00E2 Zn 99 Trb/Rst		
008D Zn 14 Trb/Rst			00B8 Zn 57 Trb/Rst			00E3 Zn 100Trb/Rst		
008E Zn 15 Trb/Rst			00B9 Zn 58 Trb/Rst			00E4 Zn 101Trb/Rst		
008F Zn 16 Trb/Rst			00BA Zn 59 Trb/Rst			00E5 Zn 102Trb/Rst		
0090 Zn 17 Trb/Rst			00BB Zn 60 Trb/Rst			00E6 Zn 103Trb/Rst		
0091 Zn 18 Trb/Rst			00BC Zn 61 Trb/Rst			00E7 Zn 104Trb/Rst		
0092 Zn 19 Trb/Rst			00BD Zn 62 Trb/Rst			00E8 Zn 105Trb/Rst		
0093 Zn 20 Trb/Rst			00BE Zn 63 Trb/Rst			00E9 Zn 106Trb/Rst		
0094 Zn 21 Trb/Rst			00BF Zn 64 Trb/Rst			00EA Zn 107Trb/Rst		
0095 Zn 22 Trb/Rst			00C0 Zn 65 Trb/Rst			00EB Zn 108Trb/Rst		
0096 Zn 23 Trb/Rst			00C1 Zn 66 Trb/Rst			00EC Zn 109Trb/Rst		
0097 Zn 24 Trb/Rst			00C2 Zn 67 Trb/Rst			00ED Zn 110Trb/Rst		
0098 Zn 25 Trb/Rst			00C3 Zn 68 Trb/Rst			00EE Zn 111Trb/Rst		
0099 Zn 26 Trb/Rst			00C4 Zn 69 Trb/Rst			00EF Zn 112Trb/Rst		
009A Zn 27 Trb/Rst			00C5 Zn 70 Trb/Rst			00F0 Zn 113Trb/Rst		
009B Zn 28 Trb/Rst			00C6 Zn 71 Trb/Rst			00F1 Zn 114Trb/Rst		
009C Zn 29 Trb/Rst			00C7 Zn 72 Trb/Rst			00F2 Zn 115Trb/Rst		
009D Zn 30 Trb/Rst			00C8 Zn 73 Trb/Rst			00F3 Zn 116Trb/Rst		
009E Zn 31 Trb/Rst			00C9 Zn 74 Trb/Rst			00F4 Zn 117Trb/Rst		
009F Zn 32 Trb/Rst			00CA Zn 75 Trb/Rst			00F5 Zn 118Trb/Rst		
00A0 Zn 33 Trb/Rst			00CB Zn 76 Trb/Rst			00F6 Zn 119Trb/Rst		
00A1 Zn 34 Trb/Rst			00CC Zn 77 Trb/Rst			00F7 Zn 120Trb/Rst		
00A2 Zn 35 Trb/Rst			00CD Zn 78 Trb/Rst			00F8 Zn 121Trb/Rst		
00A3 Zn 36 Trb/Rst			00CE Zn 79 Trb/Rst			00F9 Zn 122Trb/Rst		
00A4 Zn 37 Trb/Rst			00CF Zn 80 Trb/Rst			00FA Zn 123Trb/Rst		
00A5 Zn 38 Trb/Rst			00D0 Zn 81 Trb/Rst			00FB Zn 124Trb/Rst		
00A6 Zn 39 Trb/Rst			00D1 Zn 82 Trb/Rst			00FC Zn 125Trb/Rst		
00A7 Zn 40 Trb/Rst			00D2 Zn 83 Trb/Rst			00FD Zn 126Trb/Rst		
00A8 Zn 41 Trb/Rst			00D3 Zn 84 Trb/Rst			00FE Zn 127Trb/Rst		
00A9 Zn 42 Trb/Rst			00D4 Zn 85 Trb/Rst			00FF Zn 128Trb/Rst		
00AA Zn 43 Trb/Rst			00D5 Zn 86 Trb/Rst					

Zone X Fault/Restore

Rep #		FB	RC	Rep #		FB	RC	Rep #		FB	RC
0100	Zn 1 Ft/Rst			012B	Zn 44 Ft/Rst			0156	Zn 87 Ft/Rst		
0101	Zn 2 Ft/Rst			012C	Zn 45 Ft/Rst			0157	Zn 88 Ft/Rst		
0102	Zn 3 Ft/Rst			012D	Zn 46 Ft/Rst			0158	Zn 89 Ft/Rst		
0103	Zn 4 Ft/Rst			012E	Zn 47 Ft/Rst			0159	Zn 90 Ft/Rst		
0104	Zn 5 Ft/Rst			012F	Zn 48 Ft/Rst			015A	Zn 91 Ft/Rst		
0105	Zn 6 Ft/Rst			0130	Zn 49 Ft/Rst			015B	Zn 92 Ft/Rst		
0106	Zn 7 Ft/Rst			0131	Zn 50 Ft/Rst			015C	Zn 93 Ft/Rst		
0107	Zn 8 Ft/Rst			0132	Zn 51 Ft/Rst			015D	Zn 94 Ft/Rst		
0108	Zn 9 Ft/Rst			0133	Zn 52 Ft/Rst			015E	Zn 95 Ft/Rst		
0109	Zn 10 Ft/Rst			0134	Zn 53 Ft/Rst			015F	Zn 96 Ft/Rst		
010A	Zn 11 Ft/Rst			0135	Zn 54 Ft/Rst			0160	Zn 97 Ft/Rst		
010B	Zn 12 Ft/Rst			0136	Zn 55 Ft/Rst			0161	Zn 98 Ft/Rst		
010C	Zn 13 Ft/Rst			0137	Zn 56 Ft/Rst			0162	Zn 99 Ft/Rst		
010D	Zn 14 Ft/Rst			0138	Zn 57 Ft/Rst			0163	Zn 100Ft/Rst		
010E	Zn 15 Ft/Rst			0139	Zn 58 Ft/Rst			0164	Zn 101Ft/Rst		
010F	Zn 16 Ft/Rst			013A	Zn 59 Ft/Rst			0165	Zn 102Ft/Rst		
0110	Zn 17 Ft/Rst			013B	Zn 60 Ft/Rst			0166	Zn 103Ft/Rst		
0111	Zn 18 Ft/Rst			013C	Zn 61 Ft/Rst			0167	Zn 104Ft/Rst		
0112	Zn 19 Ft/Rst			013D	Zn 62 Ft/Rst			0168	Zn 105Ft/Rst		
0113	Zn 20 Ft/Rst			013E	Zn 63 Ft/Rst			0169	Zn 116Ft/Rst		
0114	Zn 21 Ft/Rst			013F	Zn 64 Ft/Rst			016A	Zn 107Ft/Rst		
0115	Zn 22 Ft/Rst			0140	Zn 65 Ft/Rst			016B	Zn 108Ft/Rst		
0116	Zn 23 Ft/Rst			0141	Zn 66 Ft/Rst			016C	Zn 109Ft/Rst		
0117	Zn 24 Ft/Rst			0142	Zn 67 Ft/Rst			016D	Zn 110Ft/Rst		
0118	Zn 25 Ft/Rst			0143	Zn 68 Ft/Rst			016E	Zn 111Ft/Rst		
0119	Zn 26 Ft/Rst			0144	Zn 69 Ft/Rst			016F	Zn 112Ft/Rst		
011A	Zn 27 Ft/Rst			0145	Zn 70 Ft/Rst			0170	Zn 113Ft/Rst		
011B	Zn 28 Ft/Rst			0146	Zn 71 Ft/Rst			0171	Zn 114Ft/Rst		
011C	Zn 29 Ft/Rst			0147	Zn 72 Ft/Rst			0172	Zn 115Ft/Rst		
011D	Zn 30 Ft/Rst			0148	Zn 73 Ft/Rst			0173	Zn 116Ft/Rst		
011E	Zn 31 Ft/Rst			0149	Zn 74 Ft/Rst			0174	Zn 117Ft/Rst		
011F	Zn 32 Ft/Rst			014A	Zn 75 Ft/Rst			0175	Zn 118Ft/Rst		
0120	Zn 33 Ft/Rst			014B	Zn 76 Ft/Rst			0176	Zn 119Ft/Rst		
0121	Zn 34 Ft/Rst			014C	Zn 77 Ft/Rst			0177	Zn 120Ft/Rst		
0122	Zn 35 Ft/Rst			014D	Zn 78 Ft/Rst			0178	Zn 121Ft/Rst		
0123	Zn 36 Ft/Rst			014E	Zn 79 Ft/Rst			0179	Zn 122Ft/Rst		
0124	Zn 37 Ft/Rst			014F	Zn 80 Ft/Rst			017A	Zn 123Ft/Rst		
0125	Zn 38 Ft/Rst			0150	Zn 81 Ft/Rst			017B	Zn 124Ft/Rst		
0126	Zn 39 Ft/Rst			0151	Zn 82 Ft/Rst			017C	Zn 125Ft/Rst		
0127	Zn 40 Ft/Rst			0152	Zn 83 Ft/Rst			017D	Zn 126Ft/Rst		
0128	Zn 41 Ft/Rst			0153	Zn 84 Ft/Rst			017E	Zn 127Ft/Rst		
0129	Zn 42 Ft/Rst			0154	Zn 85 Ft/Rst			017F	Zn 128Ft/Rst		
012A	Zn 43 Ft/Rst			0155	Zn 86 Ft/Rst			0180-0187	For Future Use		

Module Tamper/Restore

Rep #	FB	RC	Rep #	FB	RC	Rep #	FB	RC
0188 LCD4500Md1	_ _	_ _	0193 LCD4500Md12	_ _	_ _	019E PC41XXMd6	_ _	_ _
0189 LCD4500Md2	_ _	_ _	0194 LCD4500Md13	_ _	_ _	019F PC41XXMd7	_ _	_ _
018A LCD4500Md3	_ _	_ _	0195 LCD4500Md14	_ _	_ _	01A0 PC41XXMd8	_ _	_ _
018B LCD4500Md4	_ _	_ _	0196 LCD4500Md15	_ _	_ _	01A1 PC41XXMd9	_ _	_ _
018C LCD4500Md5	_ _	_ _	0197 LCD4500Md16	_ _	_ _	01A2 PC41XXMd10	_ _	_ _
018D LCD4500Md6	_ _	_ _	0198 PC4400Md	_ _	_ _	01A3 PC41XXMd11	_ _	_ _
018E LCD4500Md7	_ _	_ _	0199 PC41XXMd1	_ _	_ _	01A4 PC41XXMd12	_ _	_ _
018F LCD4500Md8	_ _	_ _	019A PC41XXMd2	_ _	_ _	01A5 PC41XXMd13	_ _	_ _
0190 LCD4500Md9	_ _	_ _	019B PC41XXMd3	_ _	_ _	01A6 PC41XXMd14	_ _	_ _
0191 LCD4500Md10	_ _	_ _	019C PC41XXMd4	_ _	_ _	01A7-01A8	For Future Use	
0192 LCD4500Md11	_ _	_ _	019D PC41XXMd5	_ _	_ _			
01A9 PC4216Md1	_ _	_ _	01B2 PC4204Md1	_ _	_ _	01BB PC4204Md10	_ _	_ _
01AA PC4216Md2	_ _	_ _	01B3 PC4204Md2	_ _	_ _	01BC PC4204Md11	_ _	_ _
01AB PC4216Md3	_ _	_ _	01B4 PC4204Md3	_ _	_ _	01BD PC4204Md12	_ _	_ _
01AC PC4216Md4	_ _	_ _	01B5 PC4204Md4	_ _	_ _	01BE PC4204Md13	_ _	_ _
01AD PC4216Md5	_ _	_ _	01B6 PC4204Md5	_ _	_ _	01BF PC4204Md14	_ _	_ _
01AE PC4216Md6	_ _	_ _	01B7 PC4204Md6	_ _	_ _	01C0 PC4204Md15	_ _	_ _
01AF PC4216Md7	_ _	_ _	01B8 PC4204Md7	_ _	_ _	01C1 PC4204Md16	_ _	_ _
01B0 PC4216Md8	_ _	_ _	01B9 PC4204Md8	_ _	_ _	01C2-01C9	For Future Use	
01B1 PC4216Md9	_ _	_ _	01BA PC4204Md9	_ _	_ _			

Priority Alarms

Rep #	FB	RC
01CA Fire Key Alm	_ _	_ _
01CB Aux. Key Alm	_ _	_ _
01CC Panic Key Alm	_ _	_ _
01CD Duress Alarm	_ _	_ _

Openings and Closings by User

Rep #	FB	RC	Rep #	FB	RC	Rep #	FB	RC
01CE O/C User 001			01F9 O/C User 044			0224 O/C User 087		
01CF O/C User 002			01FA O/C User 045			0225 O/C User 088		
01D0 O/C User 003			01FB O/C User 046			0226 O/C User 089		
01D1 O/C User 004			01FC O/C User 047			0227 O/C User 090		
01D2 O/C User 005			01FD O/C User 048			0228 O/C User 091		
01D3 O/C User 006			01FE O/C User 049			0229 O/C User 092		
01D4 O/C User 007			01FF O/C User 050			022A O/C User 093		
01D5 O/C User 008			0200 O/C User 051			022B O/C User 094		
01D6 O/C User 009			0201 O/C User 052			022C O/C User 095		
01D7 O/C User 010			0202 O/C User 053			022D O/C User 096		
01D8 O/C User 011			0203 O/C User 054			022E O/C User 097		
01D9 O/C User 012			0204 O/C User 055			022F O/C User 098		
01DA O/C User 013			0205 O/C User 056			0230 O/C User 099		
01DB O/C User 014			0206 O/C User 057			0231 O/C User 100		
01DC O/C User 015			0207 O/C User 058			0232 O/C User 101		
01DD O/C User 016			0208 O/C User 059			0233 O/C User 102		
01DE O/C User 017			0209 O/C User 060			0234 O/C User 103		
01DF O/C User 018			020A O/C User 061			0235 O/C User 104		
01E0 O/C User 019			020B O/C User 062			0236 O/C User 105		
01E1 O/C User 020			020C O/C User 063			0237 O/C User 106		
01E2 O/C User 021			020D O/C User 064			0238 O/C User 107		
01E3 O/C User 022			020E O/C User 065			0239 O/C User 108		
01E4 O/C User 023			020F O/C User 066			023A O/C User 109		
01E5 O/C User 024			0210 O/C User 067			023B O/C User 110		
01E6 O/C User 025			0211 O/C User 068			023C O/C User 111		
01E7 O/C User 026			0212 O/C User 069			023D O/C User 112		
01E8 O/C User 027			0213 O/C User 070			023E O/C User 113		
01E9 O/C User 028			0214 O/C User 071			023F O/C User 114		
01EA O/C User 029			0215 O/C User 072			0240 O/C User 115		
01EB O/C User 030			0216 O/C User 073			0241 O/C User 116		
01EC O/C User 031			0217 O/C User 074			0242 O/C User 117		
01ED O/C User 032			0218 O/C User 075			0243 O/C User 118		
01EE O/C User 033			0219 O/C User 076			0244 O/C User 119		
01EF O/C User 034			021A O/C User 077			0245 O/C User 120		
01F0 O/C User 035			021B O/C User 078			0246 O/C User 121		
01F1 O/C User 036			021C O/C User 079			0247 O/C User 122		
01F2 O/C User 037			021D O/C User 080			0248 O/C User 123		
01F3 O/C User 038			021E O/C User 081			0249 O/C User 124		
01F4 O/C User 039			021F O/C User 082			024A O/C User 125		
01F5 O/C User 040			0220 O/C User 083			024B O/C User 126		
01F6 O/C User 041			0221 O/C User 084			024C O/C User 127		
01F7 O/C User 042			0222 O/C User 085			024D O/C User 128		
01F8 O/C User 043			0223 O/C User 086					

Miscellaneous Openings and Closings

Rep #	FB	RC	Rep #	FB	RC	Rep #	FB	RC
024E Quick Arm	<input type="checkbox"/>	<input type="checkbox"/>	0251 Auto Arm	<input type="checkbox"/>	<input type="checkbox"/>	0254-0256 For future use		
024F Partial Closing	<input type="checkbox"/>	<input type="checkbox"/>	0252 Kypd Lockout	<input type="checkbox"/>	<input type="checkbox"/>	0257 Open after alm	<input type="checkbox"/>	<input type="checkbox"/>
0250 Auto Arm Abort	<input type="checkbox"/>	<input type="checkbox"/>	0253 O/C 2nd Mast.	<input type="checkbox"/>	<input type="checkbox"/>	0258 Auto disarm	<input type="checkbox"/>	<input type="checkbox"/>

Partition Openings and Closings

Rep #	FB	RC	Rep #	FB	RC	Rep #	FB	RC
0259 Partition 1O/C	<input type="checkbox"/>	<input type="checkbox"/>	025C Partition 4O/C	<input type="checkbox"/>	<input type="checkbox"/>	025F Partition 7O/C	<input type="checkbox"/>	<input type="checkbox"/>
025A Partition 2O/C	<input type="checkbox"/>	<input type="checkbox"/>	025D Partition 5O/C	<input type="checkbox"/>	<input type="checkbox"/>	0260 Partition 8O/C	<input type="checkbox"/>	<input type="checkbox"/>
025B Partition 3O/C	<input type="checkbox"/>	<input type="checkbox"/>	025E Partition 6O/C	<input type="checkbox"/>	<input type="checkbox"/>	0261 For Future Use	<input type="checkbox"/>	<input type="checkbox"/>

System Maintenance

Rep #	FB	RC	Rep #	FB	RC
0262 Sys batt	<input type="checkbox"/>	<input type="checkbox"/>	026C Sys test	<input type="checkbox"/>	<input type="checkbox"/>
0263 Sys AC	<input type="checkbox"/>	<input type="checkbox"/>	026D LINKS per. test	<input type="checkbox"/>	<input type="checkbox"/>
0264 Sys bell	<input type="checkbox"/>	<input type="checkbox"/>	026E Per. UL test	<input type="checkbox"/>	<input type="checkbox"/>
0265 Sys AUX sup	<input type="checkbox"/>	<input type="checkbox"/>	026F DLS lead in	<input type="checkbox"/>	<input type="checkbox"/>
0266 COMBUS Trb	<input type="checkbox"/>	<input type="checkbox"/>	0270 DLS lead out	<input type="checkbox"/>	<input type="checkbox"/>
0267 TLM line1	<input type="checkbox"/>	<input type="checkbox"/>	0271 Installer lead in	<input type="checkbox"/>	<input type="checkbox"/>
0268 TLM line2	<input type="checkbox"/>	<input type="checkbox"/>	0272 Inst. lead out	<input type="checkbox"/>	<input type="checkbox"/>
0269 FTC Rst	<input type="checkbox"/>	<input type="checkbox"/>	0273 Automation Flt	<input type="checkbox"/>	<input type="checkbox"/>
026A Sys per. test	<input type="checkbox"/>	<input type="checkbox"/>	0274-0277 For Future Use		
026B Ev. Buf. 75% fl	<input type="checkbox"/>	<input type="checkbox"/>			

PC4204 Troubles

Rep #	FB	RC	Rep #	FB	RC	Rep #	FB	RC
0278 Batt TrbMd1	<input type="checkbox"/>	<input type="checkbox"/>	0289 AUX SupMd6	<input type="checkbox"/>	<input type="checkbox"/>	029A AC TrbMd12	<input type="checkbox"/>	<input type="checkbox"/>
0279 AC TrbMd1	<input type="checkbox"/>	<input type="checkbox"/>	028A Batt TrbMd7	<input type="checkbox"/>	<input type="checkbox"/>	029B AUX SupMd12	<input type="checkbox"/>	<input type="checkbox"/>
027A AUX SupMd1	<input type="checkbox"/>	<input type="checkbox"/>	028B AC TrbMd7	<input type="checkbox"/>	<input type="checkbox"/>	029C Batt TrbMd13	<input type="checkbox"/>	<input type="checkbox"/>
027B Batt TrbMd2	<input type="checkbox"/>	<input type="checkbox"/>	028C AUX SupMd7	<input type="checkbox"/>	<input type="checkbox"/>	029D AC TrbMd13	<input type="checkbox"/>	<input type="checkbox"/>
027C AC TrbMd2	<input type="checkbox"/>	<input type="checkbox"/>	028D Batt TrbMd8	<input type="checkbox"/>	<input type="checkbox"/>	029E AUX SupMd13	<input type="checkbox"/>	<input type="checkbox"/>
027D AUX SupMd2	<input type="checkbox"/>	<input type="checkbox"/>	028E AC TrbMd8	<input type="checkbox"/>	<input type="checkbox"/>	029F Batt TrbMd14	<input type="checkbox"/>	<input type="checkbox"/>
027E Batt TrbMd3	<input type="checkbox"/>	<input type="checkbox"/>	028F AUX SupMd8	<input type="checkbox"/>	<input type="checkbox"/>	02A0 AC TrbMd14	<input type="checkbox"/>	<input type="checkbox"/>
027F AC TrbMd3	<input type="checkbox"/>	<input type="checkbox"/>	0290 Batt TrbMd9	<input type="checkbox"/>	<input type="checkbox"/>	02A1 AUX SupMd14	<input type="checkbox"/>	<input type="checkbox"/>
0280 AUX SupMd3	<input type="checkbox"/>	<input type="checkbox"/>	0291 AC TrbMd9	<input type="checkbox"/>	<input type="checkbox"/>	02A2 Batt TrbMd15	<input type="checkbox"/>	<input type="checkbox"/>
0281 Batt TrbMd4	<input type="checkbox"/>	<input type="checkbox"/>	0292 AUX SupMd9	<input type="checkbox"/>	<input type="checkbox"/>	02A3 AC TrbMd15	<input type="checkbox"/>	<input type="checkbox"/>
0282 AC TrbMd4	<input type="checkbox"/>	<input type="checkbox"/>	0293 Batt TrbMd10	<input type="checkbox"/>	<input type="checkbox"/>	02A4 AUX SupMd15	<input type="checkbox"/>	<input type="checkbox"/>
0283 AUX SupMd4	<input type="checkbox"/>	<input type="checkbox"/>	0294 AC TrbMd10	<input type="checkbox"/>	<input type="checkbox"/>	02A5 Batt TrbMd16	<input type="checkbox"/>	<input type="checkbox"/>
0284 Batt TrbMd5	<input type="checkbox"/>	<input type="checkbox"/>	0295 AUX SupMd10	<input type="checkbox"/>	<input type="checkbox"/>	02A6 AC TrbMd16	<input type="checkbox"/>	<input type="checkbox"/>
0285 AC TrbMd5	<input type="checkbox"/>	<input type="checkbox"/>	0296 Batt TrbMd11	<input type="checkbox"/>	<input type="checkbox"/>	02A7 AUX SupMd16	<input type="checkbox"/>	<input type="checkbox"/>
0286 AUX SupMd5	<input type="checkbox"/>	<input type="checkbox"/>	0297 AC TrbMd11	<input type="checkbox"/>	<input type="checkbox"/>	02A8 For future use	<input type="checkbox"/>	<input type="checkbox"/>
0287 Batt TrbMd6	<input type="checkbox"/>	<input type="checkbox"/>	0298 AUX SupMd11	<input type="checkbox"/>	<input type="checkbox"/>			
0288 AC TrbMd6	<input type="checkbox"/>	<input type="checkbox"/>	0299 Batt TrbMd12	<input type="checkbox"/>	<input type="checkbox"/>			

Fire Module

Rep #	FB	RC	Rep #	FB	RC
02A9 2-wire smk alm	<input type="checkbox"/>	<input type="checkbox"/>	02AB 2-wire smk rst	<input type="checkbox"/>	<input type="checkbox"/>
02AA Water flow alm	<input type="checkbox"/>	<input type="checkbox"/>	02AC Water flow trb	<input type="checkbox"/>	<input type="checkbox"/>
			02AD Ground fault	<input type="checkbox"/>	<input type="checkbox"/>

Wireless – Low Battery

Rep #	FB	RC	Rep #	FB	RC	Rep #	FB	RC
02AE Zn 01 low batt	_____	_____	02C4 Zn 23 low batt	_____	_____	02DA Zn 45 low batt	_____	_____
02AF Zn 02 low batt	_____	_____	02C5 Zn 24 low batt	_____	_____	02DB Zn 46 low batt	_____	_____
02B0 Zn 03 low batt	_____	_____	02C6 Zn 25 low batt	_____	_____	02DC Zn 47 low batt	_____	_____
02B1 Zn 04 low batt	_____	_____	02C7 Zn 26 low batt	_____	_____	02DD Zn 48 low batt	_____	_____
02B2 Zn 05 low batt	_____	_____	02C8 Zn 27 low batt	_____	_____	02DE Zn 49 low batt	_____	_____
02B3 Zn 06 low batt	_____	_____	02C9 Zn 28 low batt	_____	_____	02DF Zn 50 low batt	_____	_____
02B4 Zn 07 low batt	_____	_____	02CA Zn 29 low batt	_____	_____	02E0 Zn 51 low batt	_____	_____
02B5 Zn 08 low batt	_____	_____	02CB Zn 30 low batt	_____	_____	02E1 Zn 52 low batt	_____	_____
02B6 Zn 09 low batt	_____	_____	02CC Zn 31 low batt	_____	_____	02E2 Zn 53 low batt	_____	_____
02B7 Zn 10 low batt	_____	_____	02CD Zn 32 low batt	_____	_____	02E3 Zn 54 low batt	_____	_____
02B8 Zn 11 low batt	_____	_____	02CE Zn 33 low batt	_____	_____	02E4 Zn 55 low batt	_____	_____
02B9 Zn 12 low batt	_____	_____	02CF Zn 34 low batt	_____	_____	02E5 Zn 56 low batt	_____	_____
02BA Zn 13 low batt	_____	_____	02D0 Zn 35 low batt	_____	_____	02E6 Zn 57 low batt	_____	_____
02BB Zn 14 low batt	_____	_____	02D1 Zn 36 low batt	_____	_____	02E7 Zn 58 low batt	_____	_____
02BC Zn 15 low batt	_____	_____	02D2 Zn 37 low batt	_____	_____	02E8 Zn 59 low batt	_____	_____
02BD Zn 16 low batt	_____	_____	02D3 Zn 38 low batt	_____	_____	02E9 Zn 60 low batt	_____	_____
02BE Zn 17 low batt	_____	_____	02D4 Zn 39 low batt	_____	_____	02EA Zn 61 low batt	_____	_____
02BF Zn 18 low batt	_____	_____	02D5 Zn 40 low batt	_____	_____	02EB Zn 62 low batt	_____	_____
02C0 Zn 19 low batt	_____	_____	02D6 Zn 41 low batt	_____	_____	02EC Zn 63 low batt	_____	_____
02C1 Zn 20 low batt	_____	_____	02D7 Zn 42 low batt	_____	_____	02ED Zn 64 low batt	_____	_____
02C2 Zn 21 low batt	_____	_____	02D8 Zn 43 low batt	_____	_____			
02C3 Zn 22 low batt	_____	_____	02D9 Zn 44 low batt	_____	_____			

Wireless – Supervisory Fault

Rep #	FB	RC	Rep #	FB	RC	Rep #	FB	RC
02EE Zn 01 superv.	_____	_____	0304 Zn 23 superv.	_____	_____	031A Zn 45 superv.	_____	_____
02EF Zn 02 superv.	_____	_____	0305 Zn 24 superv.	_____	_____	031B Zn 46 superv.	_____	_____
02F0 Zn 03 superv.	_____	_____	0306 Zn 25 superv.	_____	_____	031C Zn 47 superv.	_____	_____
02F1 Zn 04 superv.	_____	_____	0307 Zn 26 superv.	_____	_____	031D Zn 48 superv.	_____	_____
02F2 Zn 05 superv.	_____	_____	0308 Zn 27 superv.	_____	_____	031E Zn 49 superv.	_____	_____
02F3 Zn 06 superv.	_____	_____	0309 Zn 28 superv.	_____	_____	031F Zn 50 superv.	_____	_____
02F4 Zn 07 superv.	_____	_____	030A Zn 29 superv.	_____	_____	0320 Zn 51 superv.	_____	_____
02F5 Zn 08 superv.	_____	_____	030B Zn 30 superv.	_____	_____	0321 Zn 52 superv.	_____	_____
02F6 Zn 09 superv.	_____	_____	030C Zn 31 superv.	_____	_____	0322 Zn 53 superv.	_____	_____
02F7 Zn 10 superv.	_____	_____	030D Zn 32 superv.	_____	_____	0323 Zn 54 superv.	_____	_____
02F8 Zn 11 superv.	_____	_____	030E Zn 33 superv.	_____	_____	0324 Zn 55 superv.	_____	_____
02F9 Zn 12 superv.	_____	_____	030F Zn 34 superv.	_____	_____	0325 Zn 56 superv.	_____	_____
02FA Zn 13 superv.	_____	_____	0310 Zn 35 superv.	_____	_____	0326 Zn 57 superv.	_____	_____
02FF Zn 14 superv.	_____	_____	0311 Zn 36 superv.	_____	_____	0327 Zn 58 superv.	_____	_____
02FC Zn 15 superv.	_____	_____	0312 Zn 37 superv.	_____	_____	0328 Zn 59 superv.	_____	_____
02FD Zn 16 superv.	_____	_____	0313 Zn 38 superv.	_____	_____	0329 Zn 60 superv.	_____	_____
02FE Zn 17 superv.	_____	_____	0314 Zn 39 superv.	_____	_____	032A Zn 61 superv.	_____	_____
02FF Zn 18 superv.	_____	_____	0315 Zn 40 superv.	_____	_____	032B Zn 62 superv.	_____	_____
0300 Zn 19 superv.	_____	_____	0316 Zn 41 superv.	_____	_____	032C Zn 63 superv.	_____	_____
0301 Zn 20 superv.	_____	_____	0317 Zn 42 superv.	_____	_____	032D Zn 64 superv.	_____	_____
0302 Zn 21 superv.	_____	_____	0318 Zn 43 superv.	_____	_____			
0303 Zn 22 superv.	_____	_____	0319 Zn 44 superv.	_____	_____			

Police Code (PC)

Rep #	FB	RC	Rep #	FB	RC	Rep #	FB	RC
032E Partition 1 PC	_____	_____	0331 Partition 4 PC	_____	_____	0334 Partition 7 PC	_____	_____
032F Partition 2 PC	_____	_____	0332 Partition 5 PC	_____	_____	0335 Partition 8 PC	_____	_____
0330 Partition 3 PC	_____	_____	0333 Partition 6 PC	_____	_____	0336-337 For future use		

DVAC Module

0338 Line fault	_____	_____	033A Shutdown by CSI	_____	_____
0339 Module fault	_____	_____	033B Bypassed zns	_____	_____

DVAC Identifiers

Function Bytes

For alarm reports, bit number 7 of the function byte determines the status of the each printed event.

Alarm Function Bytes

In the following list, there are two entries for each event in the Function Byte column. The first number corresponds to an alarm; the second corresponds to the restoral. Each event will thus be printed in one of two ways. For example:

06 Burglar Alm ZnXXX BA XXX This event is an alarm.
86 Burglar Rst ZnXXX BH XXX This event is a restore.

Function Byte	Printer Message	Computer Message	Function Byte	Printer Message	Computer Message
00/80	Fire*	FA/FH 000-999	11/91	24 hrs*	UA/UH 000-999
01/81	Sprnklr*	SA/SH 000-999	12/92	System*	UA/UH 000-999
02/82	Panic*	PA/PH 000-999	13/93	Auxil.*	UA/UH 000-999
03/83	Hold up*	HA/HH 000-999	14/94	Untyped*	UA/UH 000-999
04/84	Medical*	MA/MH 000-999	15/95	-----*	UA/UH 000-999
05/85	Emergen*	QA/QH 000-999	16/96	24hrLat*	TA/TR 000-999
06/86	Burglar*	BA/BH 000-999	17/97	Tamper*	TA/TR 000-999
07/87	DelayHA*	BA/BH 000-999	18/98	Supervi *	UA/UH 000-999
08/88	Delay*	BA/BH 000-999	19	BrgVerf*	BV 000-999
09/89	Instant*	BA/BH 000-999	1A/9A	-----*	UA/UH 000-999
0A/8A	Interio*	BA/BH 000-999	1B/9B	-----*	UA/UH 000-999
0B/8B	InterHA*	BA/BH 000-999	1C/9C	-----*	UA/UH 000-999
0C/8C	Motion*	BA/BH 000-999	1D/9D	Test*	UX/UR 000-999
0D/8D	Water*	WA/WH 000-999	1E/9E	Unsecur *	YY/UR 000-999
0E/8E	Freeze*	ZA/ZH 000-999	1F/9F	Cancel*	OC/OC 000-999
0F/8F	Gas*	GA/GH 000-999			
10/90	Heat*	KA/KH 000-999			

*The zone number of each alarm and restoral will also be printed in the form of "Alm/Rst Zn000-999".

Trouble Function Bytes

In the following list, there are two entries for each event in the Function Byte column. The first number corresponds to a trouble; the second corresponds to the trouble restoral. Each event will thus be printed in one of two ways. For example:

26 Burglar Trb Zn001 BT 001 This event is a trouble.
A6 Burglar T_R Zn001 BJ 001 This event is a trouble restoral.

Function Byte	Printer Message	Computer Message	Function Byte	Printer Message	Computer Message
20/A0	Fire*	FT/FJ 000-999	32/B2	System*	UT/UJ 000-999
21/A1	Sprinkl*	ST/SJ 000-999	33/B3	Auxil.*	UT/UJ 000-999
22/A2	Panic*	PT/PJ 000-999	34/B4	Untyped*	UT/UJ 000-999
23/A3	Hold up*	HT/HJ 000-999	35/B5	-----*	UT/UJ 000-999
24/A4	Medical*	MT/MJ 000-999	36/B6	24hrLat*	UT/UJ 000-999
25/A5	Emergen*	QT/QJ 000-999	37/B7	Tamper*	UT/UJ 000-999
26/A6	Burglar*	BT/BJ 000-999	38/B8	Supervi*	UT/UJ 000-999
27/A7	DelayHA*	BT/BJ 000-999	39/B9	Expans.*	ET/ER 000-999
28/A8	Delay*	BT/BJ 000-999	3A/BA	AC Cut*	AT/AR 000-999
29/A9	Instant*	BT/BJ 000-999	3B/BB	WirLBat*	XT/XR 000-999
2A/AA	Interio*	BT/BJ 000-999	3C/BC	PwSupply*	YP/YQ 000-999
2B/AB	InterHA*	BT/BJ 000-999	3D/BD	SysLBat*	YT/YR 000-999
2C/AC	Motion*	BT/BJ 000-999	3E/BE	Line*	LT/LR 000-999
2D/AD	Water*	WT/WJ 000-999	3F/BF	ZnFault*	UT/UJ 000-999
2E/AE	Freeze*	ZT/ZJ 000-999			
2F/AF	Gas*	GT/GJ 000-999			
30/B0	Heat*	KT/KJ 000-999			
31/B1	24 hrs*	UT/UJ 000-999			

*The zone number of each trouble and trouble restoral will also be printed in the form of "Trb/T_R Zn000-999".

Bypass Function Bytes

In the following list, there are two entries for each event in the Function Byte column. The first number corresponds to the bypassing of a zone; the second corresponds to the unbypassing. Each event will thus be printed in one of two ways.

For example:

46	Burglar	Byp ZnXXX	BB XXX	This event is a bypass.
C6	Burglar	Unb ZnXXX	BU XXX	This event is an unbypass.

Function Byte	Printer Message	Computer Message	Function Byte	Printer Message	Computer Message
40/C0	Fire*	FB/FU 000-999	51/D1	24 Hrs*	UB/UU 000-999
41/C1	Sprnklr *	SB/SU 000-999	52/D2	System*	UB/UU 000-999
42/C2	Panic*	PB/PU 000-999	53/D3	Auxil.*	UB/UU 000-999
43/C3	Hold up*	HB/HU 000-999	54/D4	Untyped*	UB/UU 000-999
44/C4	Medical*	MB/MU 000-999	55/D5	-----*	UB/UU 000-999
45/C5	Emergen*	QB/QU 000-999	56/D6	24hrLat*	TB/TU 000-999
46/C6	Burglar*	BB/BU 000-999	57/D7	Tamper*	TB/TU 000-999
47/C7	DelayHA*	BB/BU 000-999	58/D8	Supervi *	UB/UU 000-999
48/C8	Delay*	BB/BU 000-999	59/D9	Group*	UB/UU 000-999
49/C9	Instant*	BB/BU 000-999	5A/DA	-----*	UB/UU 000-999
4A/CA	Interio*	BB/BU 000-999	5B/DB	-----*	UB/UU 000-999
4B/CB	InterHA*	BB/BU 000-999	5C/DC	-----*	UB/UU 000-999
4C/CC	Motion*	BB/BU 000-999	5D/DD	-----*	UB/UU 000-999
4D/CD	Water*	WB/WU 000-999	5E/DE	-----*	UB/UU 000-999
4E/CE	Freeze*	ZB/ZU 000-999	5F/DF	-----*	UB/UU 000-999
4F/CF	Gas*	GB/GU 000-999			
50/D0	Heat*	KB/KU 000-999			

*The zone number of each alarm and restoral will also be printed in the form of "Byp/Unb Zn000-999".

Supervisory Function Bytes

In the following list, there are two entries for each event in the Function Byte column. The first number corresponds a supervisory; the second corresponds to a supervisory restoral. Each event will thus be printed in one of two ways.

For example:

66	Burglar	Sup Zn001	BS 001	This event is a supervisory.
E6	Burglar	S_R Zn001	BJ 001	This event is an supervisory restore.

Function Byte	Printer Message	Computer Message	Function Byte	Printer Message	Computer Message
60/E0	Fire*	FS/FJ 000-999	6C/EC	Motion*	BS/BJ 000-999
61/E1	Sprinkl*	SS/SJ 000-999	6D/ED	Water*	WS/WJ 000-999
62/E2	Panic*	PS/PJ 000-999	6E/EE	Freeze*	ZS/ZJ 000-999
63/E3	Hold up*	HS/HJ 000-999	6F/EF	Gas*	GS/GJ 000-999
64/E4	Medical*	MS/MJ 000-999	70/F0	Heat*	KS/KJ 000-999
65/E5	Emergen*	QS/QJ 000-999	71/F1	24 Hrs *	US/UJ 000-999
66/E6	Burglar*	BS/BJ 000-999	72/F2	System*	US/UJ 000-999
67/E7	DelayHA*	BS/BJ 000-999	73/F3	Auxil.*	US/UJ 000-999
68/E8	Delay*	BS/BJ 000-999	74/F4	Untyped*	US/UJ 000-999
69/E9	Instant*	BS/BJ 000-999	75/F5	-----*	US/UJ 000-999
6A/EA	Interio*	BS/BJ 000-999			
6B/EB	InterHA*	BS/BJ 000-999			

*The zone number of each alarm and restoral will also be printed in the form of "Sup/S_R Zn000-999".

Opening and Closing Function Bytes

In the following list, there are two entries for each event in the Function Byte column. The first number corresponds an opening; the second corresponds to a closing. Each event will thus be printed in one of two ways. For example:

76	Open User XXX	OP XXX	This event is a opening.
F6	Close User XXX	CL XXX	This event is an closing.

Function Byte	Printer Message	Computer Message
76/F6	Open/Close User000-999	OP/CL 000-999
77/F7	Open/Close Group000-999	OG/CG 000-999

Miscellaneous Function Bytes

Function Byte	Printer Message	Computer Message
78/F8	By User 000-999	No transmission
79/F9	Control Act/Rst Pt000-999	RC/RO 000-999
7A/FA	Service Req/Req Zn000-999	YX/YX 000-999
7B/FB	Dealer Id/Id 000-999	DU/DU 000-999
7C/FC	User Msg/Msg Zn000-999	CE/CE 000-999
7D/FD	Instal Msg/Msg Zn000-999	DU/DU 000-999

Reserved function bytes : 7F/FF**7E/FE : Specific Message Function Byte**

Since there is no zone or user number which needs to be programmed for the messages attributed to function byte 7E/FE, the zone number refers to the printed message transmitted to the computer. The zone number sent to the computer for each event is always 000.

Zn#	Printer MSG	Computer MSG	Zn#	Printer MSG	Computer MSG	Zn#	Printer MSG	Computer MSG
001	Automat Closing	CA	025	Door Station	DS	049	Remote P.Success	RS
002	Automat Open	OA	026	Alm On Exit	UA	050	Remote P.Fail	RU
003	Closing Extend	CE	027	Fire test begin	FI	051	Remote Reset	RN
004	Partial Closing	CG	028	Fire test end	FK	052	Power Up	RR
005	Forced Closing	CF	029	User cd Tamper	JA	053	Data Lost	RT
006	Forced arming	CW	030	Log Threshold	JL	054	Automatic Test	RP
007	Fail to Close	CI	031	Log Overflow	JO	055	Manual Test	RX
008	Fail to Open	OI	032	Schedul Execute	JR	056	Test Start	TS
009	Late Close	CJ	033	Schedul Change	JS	057	Test End	TE
010	Late Open	OJ	034	Time Changed	JT	058	Printer Papr In	VI
011	Late to Close	OT	035	Date Changed	JD	059	Printer Papr Out	VO
012	Late to Open	CT	036	Holiday Changed	JH	060	Printer Restore	VR
013	Early Close	CK	037	User cd Changed	JV	061	Printer Trouble	VT
014	Early Open	OK	038	User cd Deleted	JX	062	Printer Test	VX
015	F. Arm Perimeter	NF	039	Local Prg Begin	LB	063	Printer On Line	VY
016	Perimeter Arm	NL	040	Local Prg Denied	LD	064	Printer Off Line	VZ
017	Disarm From Alm	OR	041	Local Prg Succes	LS	065	Extra Point	XE
018	Access Closed	DC	042	Local Prg Fail	LU	066	Extra RF Point	XF
019	Access Denied	DD	043	Local Prg Ended	LX	067	Sensor Reset	XI
020	Access Granted	DG	044	Listen-In begin	LF	068	Forced Point	XW
021	Access Lockout	DK	045	Listen-In ended	LE	069	Watch Dog Reset	YW
022	Access Open	DO	046	Remote P.C.F	RA	070	Service Required	YX
023	Access Trouble	DT	047	Remote P.begin	RB	071	Status Report	YY
024	Door Forced	DF	048	Remote P.Denied	RD	072	Downlook Start	None



©2001 Digital Security Controls Ltd.

Toronto, Canada

www.dsc.com • 1-800-387-3630

Printed in Canada 29002039 R003